



**EFFECTIVE FROM
JANUARY 2024**

EXPORT CATALOGUE
TESTING EQUIPMENT
AND ORIGINAL ACCESSORIES



REL. MAY 2024

COLOR TABLE

- 1) The standard company colour of our equipment is blue RAL 2004 /60 or /61 orange peel).
- 2) On demand other colours are available (see RAL table)*.

• Below the table for the colors:

	→ /25	RAL 5015 Blue sky
	→ /A4	RAL 5011 Blue (Peugeot)
	→ /22	RAL 5011 Blue (Peugeot) orange-peel
	→ /16	RAL 3002 Red
	→ /45	RAL 1003 Yellow (Renault)
	→ /38	RAL 7042 Grey (Renault)
	→ /39	RAL 7040 Window grey (Volkswagen / Porsche / Fiat)
	→ /33	RAL 7011 Grey (Mercedes)
	→ /65	RAL 7012 Grey (Mercedes)
	→ /52	RAL 7015 Grey (Mercedes)
	→ /69	RAL 7030 Stone grey (Ferrari / Maserati)
	→ /34	RAL 7016 Anthracite grey (BMW)

• Different colors subject to confirmation of the Export dept.

* : The equipment in different color than standard can be subject to surcharge.

The pictures included in the present illustrated catalogue, are only intended to show the product and are therefore not binding. The company reserves the right to make in every moment and without prior notice, any modification deemed necessary.

NEXION S.p.A. declines any responsibility for any complaint coming from the use of not original accessories or spares with consequent forfeiture of the CE conformity declaration.

TABLE OF CONTENTS

ROLLER BRAKE TESTERS FOR TRUCKS AND BUSES	4	CAMERA HEAD LIGHT TESTERS	37
VIDEOSYSTEM P150-2V - 4WD	4	PFT-CAM	37
VIDEOSYSTEM P110	5	ACCESSORIES FOR CAMERA HEAD LIGHT TESTERS	38
OPTIONALS FOR TRUCK ROLLER BRAKE TESTERS	6		
ADDITIONAL EQUIPMENT FOR TRUCK INSPECTION LINES	9		
		DIGITAL HEAD LIGHT TESTERS	39
ROLLER BRAKE TESTERS FOR CARS AND VANS	10	LOOK "LS"	39
VIDEOSYSTEM W	10	LOOK "OPT"	40
COMPACT PRO W	11	ACCESSORIES FOR DIGITAL HEAD LIGHT TESTERS	41
COMPULSORY DEVICES FOR CAR AND VAN ROLLER BRAKE TESTERS	12		
OPTIONAL ACCESSORIES FOR CAR AND VAN ROLLER BRAKE TESTERS	14	GAS ANALYSERS	42
ADDITIONAL EQUIPMENT FOR PASSENGER CAR INSPECTION LINES	17	810 - 830	42
PASSENGER CAR INSPECTION LINES	19	ACCESSORIES FOR 810 AND 830 GAS ANALYSERS	43
		COMPLETE CONFIGURATIONS FOR 810 AND 830 GAS ANALYSERS	45
UNIVERSAL ROLLER BRAKE TESTERS FOR 2/3/4-WHEEL VEHICLES	22	SMOKE METERS	46
VS UNIVERSAL	22	820 - 840	46
VS B UNIVERSAL	23	ACCESSORIES FOR 820 AND 840 SMOKE METERS	47
COMPLETION DEVICES FOR VS UNIVERSAL	24	COMPLETE CONFIGURATIONS FOR 820 AND 840 SMOKE METERS	49
ROLLER BRAKE TESTERS FOR BIKES	27	REV COUNTER	50
COMPACT PRO MOTO	27	RPM COUNTER 165	50
OPTIONAL ACCESSORIES FOR BIKE ROLLER BRAKE TESTERS	28	ACCESSORIES FOR RPM COUNTER 165	51
ADDITIONALS EQUIPMENT FOR BIKE INSPECTION LINES	29	DIAGRAM OF PACKING SPECIFICATION	52
SUSPENSION TESTERS FOR PASSENGER CARS AND VANS	31		
COMPACT PRO W ST-NX	31		
OPTIONAL ACCESSORIES FOR COMPACT PRO W ST-NX	33		
UNIVERSAL PLAY DETECTOR	34		
PD 689533	34		
ACCESSORIES FOR UNIVERSAL PLAY DETECTOR	35		
PASSENGER CAR PLAY DETECTOR	36		
PD 622	36		



 : New or Modified Item

ROLLER BRAKE TESTERS FOR TRUCKS AND BUSES



VIDEOSYSTEM P150-2V - 4WD



Main features:

- PC with DVD and WINDOWS-based software
- "HELP" program is built-in and accessed by the operator before and after testing.
- INKJET Color A4 printer (On request).
- PC type alphanumeric keyboard, with "track-ball", for data input and test sequence selection.
- "Reverse" system for 4WD vehicles. Operational program automatic or manual.
- IEC standard electric panel.
- Automatic stop of rollers on the adherence limit.
- Radio remote control and pedal brake pressure meter included.

Instrument cabinet

- Built-in 22" LCD colour monitor.
- Two rotation speeds.

Roller bed

- Twin roller bed
- Max. weight per axle: 20.000 Kg
- Geared motors: self-braking 2x5,5/15 kW
- Two rotation speeds:
 - 2,5 km/h for vehicles > 3,5 t
 - 5 km/h for vehicles < 3,5 t
- Shifted rollers L=1070 x D.250 mm
- Special plastic cement - coating gritted rollers
- Adherence coefficient: 0,8
- High precision strain gauge transducers

- Max braking force: 4000 daN

Supplied with:
- Operator's manual.



VIDEOSYSTEM P150-2V - 4WD

PN	Power supply	Description
0-61201701/61	400V/3Ph/50Hz	VIDEOSYSTEM P150-2V - Instrument cabinet
8-61200308	400V/3Ph/50Hz	Roller bed 15 kW - Two speed



: New or Modified Item

WARNING! For different voltages a surcharge will be applied.

ROLLER BRAKE TESTERS FOR TRUCKS AND BUSES



VIDEOSYSTEM P110 - 4WD



Main features:

- PC with DVD and WINDOWS-based software
- "HELP" program is built-in and accessed by the operator before and after testing.
- INKJET Color A4 printer (On request).
- PC type alphanumeric keyboard, with "track-ball", for data input and test sequence selection.
- "Reverse" system for 4WD vehicles. Operational program automatic or manual.
- IEC standard electric panel.
- Automatic stop of rollers on the adherence limit.
- Radio remote control and pedal brake pressure meter included.

Instrument cabinet

- Built-in 22" LCD colour monitor.

Roller bed

- Twin roller bed
- Max. weight per axle: 20.000 Kg
- Geared motors: self-braking 2x11 kW
- Rotation speeds: 2 km/h
- Shifted rollers L=1070 x D.250 mm
- Special plastic cement - coating gritted rollers
- Adherence coefficient: 0,8
- High precision strain gauge transducers
- Weighing unit for truck axles included

- Max braking force: 4000 daN

Supplied with:
- Operator's manual.



VIDEOSYSTEM P110



PN	Power supply	Description
0-61201601/61	400V/3Ph/50Hz	VIDEOSYSTEM P110 - Instrument cabinet
8-61200280	400V/3Ph/50Hz	Roller bed 11 kW

WARNING! For different voltages a surcharge will be applied.



: New or Modified Item

OPTIONALS FOR TRUCK ROLLER BRAKE TESTERS

PN	Picture	Description
8-61200178/61		<p>AR 420 Analog repeater unit from brake tester for cars or trucks. Configured for fully AUTOMATIC operation. No one control need.</p> <p>Functional features:</p> <ul style="list-style-type: none"> - Resolution of braking forces: 100 N - Analog instruments diameter: 420 mm. - Indicators length: 210 mm. - Measure angular arc: 270° - Display: 6 digit, LED 7 segments, dim. (hxl): 110 x 50 mm. - Signal light
8-61200179/61		<p>Floor support for AR 420 The relevant support is available for installing the analog repeater unit on the floor.</p>
8-61200180		<p>Wall support for AR420. Suitable for wall-mounted installation.</p>

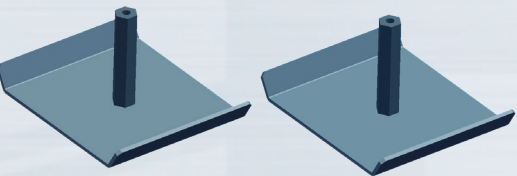
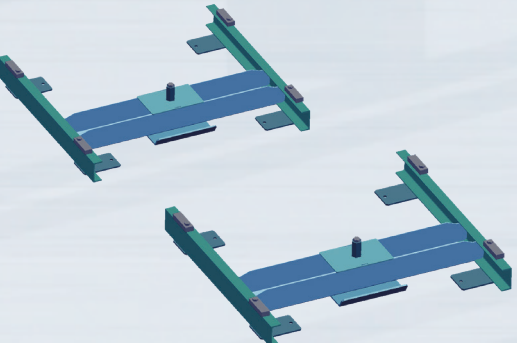
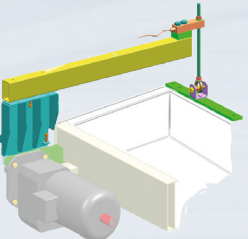

OPTIONALS FOR TRUCK ROLLER BRAKE TESTERS

PN	Picture	Description
8-61200503		A4 color inkjet printer set - USB Connection.
8-61200109		Pair of fixing basis for calibration device of weighing unit.
8-61200092		Pair of frames for truck roller bed - "5000 Series" without welded frame. (Supplied with fixing basis for calibration device of weighing unit).
8-61200001		Calibration device of braking force. To match with digital display kit PN. 806269909.

OPTIONALS FOR TRUCK ROLLER BRAKE TESTERS

PN	Picture	Description
806269021		Calibration device of weighing unit. To match with digital display kit PN. 806269909.
806269909		Digital display kit with load cell up to 5000 kg - Certification included. To match with calibration devices PN. 806269021 and 8-61200001.
5141000009		Set of safety doors for cabinet for VIDEOSYSTEM.

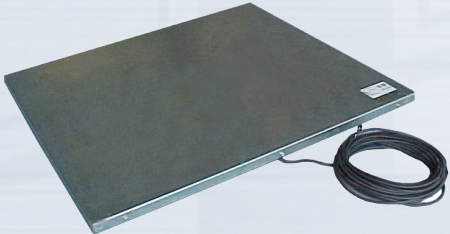
ADDITIONAL EQUIPMENT FOR TRUCK INSPECTION LINES

PN	Picture	Description	
520300009		<p>Side slip plate. Capacity 8 T (connecting wire: 15 m). For truck inspection lines only. "Flush" installation.</p>	
8-61220014		<p>P1 NG Brake pressure tester and receiver.</p>	
8-61220015		<p>Additional pressure transducer (P2 or P3 NG). Suitable for tester PN. 8-61220014.</p>	

ROLLER BRAKE TESTERS FOR CARS AND VANS



VIDEOSYSTEM W



Main features:

- PC with DVD WINDOWS-based software.
- "HELP" program is built-in and accessed by the operator before and after testing.
- PC type alphanumeric keyboard, with "track-ball", for data input and test sequence selection.
- "Reverse" system for 4WD vehicles. Operational program automatic or manual.
- IEC standard electric panel.
- Automatic stop of rollers on the adherence limit.
- Radio remote control (optional).
- Amplification electronic board inside the bench.

PC INCLUDED!

REMOTE CONTROL KIT NOT INCLUDED!

Instrument cabinet

Built-in 22" LCD colour monitor.

Inkjet colour A4 printer (Optional).

WARNING! Roller bed (for all models) is not included in the standard configuration.
Please complete the order with the "compulsory devices" dedicated section.

Supplied with:
- Operator's manual.



VIDEOSYSTEM W

PN	Power supply	Description
6111200102/61	400V/3Ph/50Hz	VIDEOSYSTEM W - EXP - Instrument cabinet

WARNING! For different voltages a surcharge will be applied.



 : New or Modified Item

ROLLER BRAKE TESTERS FOR CARS AND VANS



COMPACT PRO W



Main features:

- PC with DVD WINDOWS-based software.
- "HELP" program is built-in and accessed by the operator before and after testing.
- PC type alphanumeric keyboard, with "track-ball", for data input and test sequence selection.
- "Reverse" system for 4WD vehicles. Operational program automatic or manual.
- IEC standard electric panel.
- Automatic stop of rollers on the adherence limit.
- Radio remote control (optional).
- Amplification electronic board inside the bench.

PC INCLUDED!

MONITOR AND PRINTER NOT INCLUDED!

REMOTE CONTROL KIT NOT INCLUDED!

WARNING!

Roller bed and monitor are not included in the standard configuration. Please complete the order with the "compulsory devices" and "optional accessories" dedicated section.

Supplied with:
- Operator's manual.



COMPACT PRO W

PN	Power supply	Description
6111210102/61	400V/3Ph/50Hz	COMPACT PRO W - EXP - Instrument cabinet



 : New or Modified Item

COMPULSORY DEVICES FOR CAR AND VAN ROLLER BRAKE TESTERS

PN	Picture	Description
8-61200023	 <p>3Ph/ 400 V / 50 Hz</p>	<p>SELF-BRAKING ROLLER BED</p> <ul style="list-style-type: none"> - Single bed set, - Max. weight: 3000 kg, - Geared motors: Self-braking 2x4 kW, - Rotation speed: 5 km/h, - Shifted rollers L=700 x D.200 mm. - Special plastic cement - coating gritted rollers. - Adherence coefficient: 0,8 - High precision strain gauge transducers. <p>• Max braking force: 600 daN</p>
8-61200022	 <p>3Ph/ 400 V / 50 Hz</p>	<p>ROLLER BED</p> <ul style="list-style-type: none"> - Single bed set, - Max. weight: 3000 kg, - Geared motors: 2x4 kW, - Rotation speed: 5 km/h, - Shifted rollers L=700 x D.200 mm. - Special plastic cement - coating gritted rollers. - Adherence coefficient: 0,8 - High precision strain gauge transducers.
8-61200024	 <p>3Ph/ 400 V / 50 Hz</p>	<p>"ICE" SELF-BRAKING ROLLER BED</p> <p>As above with "ICE" self-braking roller bed. With electrically welded coating rollers for spiked tyres.</p> <p>• Max braking force: 600 daN</p>

COMPULSORY DEVICES FOR CAR AND VAN ROLLER BRAKE TESTERS

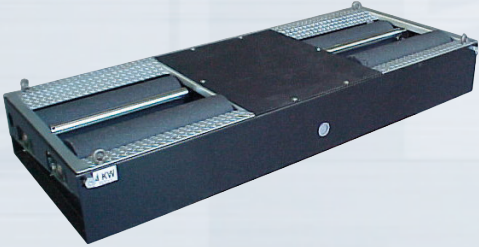
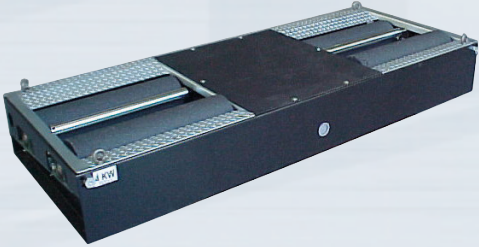
PN	Picture	Description
8-61200229	 <p>3Ph/400v/50Hz</p>	<p>ROLLER BED</p> <ul style="list-style-type: none"> - Single bed set, - Max. weight: 2500 kg, - Geared motors: 2x3 kW, - Rotation speed: 5 km/h, - Shifted rollers L=700 x D.200 mm. - Special plastic cement - coating gritted rollers. - Adherence coefficient: 0,8 - High precision strain gauge transducers. <p>• Max braking force: 600 daN</p>
8-61200269	 <p>3Ph/400v/50Hz</p>	<p>"NFR" ROLLER BED</p> <ul style="list-style-type: none"> - Single bed set, - Max. weight: 3000 kg, - Geared motors: 2x5,5 kW, - Rotation speed: 5 km/h, - Shifted rollers L=700 x D.200 mm. - Special plastic cement - coating gritted rollers. - Adherence coefficient: 0,8 - High precision strain gauge transducers. <p>Homol. certificate: FR 06-62/BVL</p> <p>• Max braking force: 800 daN</p>

OPTIONAL ACCESSORIES FOR CAR AND VAN ROLLER BRAKE TESTERS

PN	Picture	Description
8-61200503		A4 color inkjet printer set - USB Connection.
8-21100235		19" Widescreen LCD monitor for COMPACT PRO W.
8-61200143		LCD monitor support.
8-61100086		CT universal radio remote control set. Suitable for: VIDEOSYSTEM and COMPACT PRO W. RADIO SYSTEM: USE IN ACCORDING TO THE LOCAL RULES !.
8-61200146		Infrared remote control set. Suitable for: VIDEOSYSTEM and COMPACT PRO W.

OPTIONAL ACCESSORIES FOR CAR AND VAN ROLLER BRAKE TESTERS

PN	Picture	Description
806468073		Set of pedal and hand brake pressure meter.
806248012		Passenger car weighing device for single wheel. Suitable for flush installation.
8-61200027		Passenger car axle weighing unit. Flush installation under roller bed. Max. full scale value 2000 kg. per axle - Max. transit-up capacity 3000 kg. per axle.
8-61200125		Pair of cables for motors connection.
806269369		Calibration device of under roller weighing unit. o match with digital display kit PN. 806268587.
806269370		Calibration device of braking force. To match with digital display kit PN. 806268587.

OPTIONAL ACCESSORIES FOR CAR AND VAN ROLLER BRAKE TESTERS

PN	Picture	Description
806268587		Digital display kit with load cell up to 2000 kg. Certification included. To match with calibration devices PN. 806269369, 806269370 and 806269367.
511800009		Calibration device for braking force.
514100009		Set of safety doors for cabinet for VIDEOSYSTEM.
511900009		Set of roller covers for 4 kW and 3 kW models. Max transit-up 3000 kg. per axle.

ADDITIONAL EQUIPMENT FOR PASSENGER CAR INSPECTION LINES

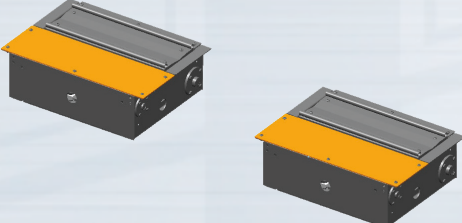
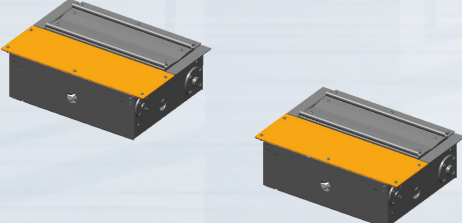
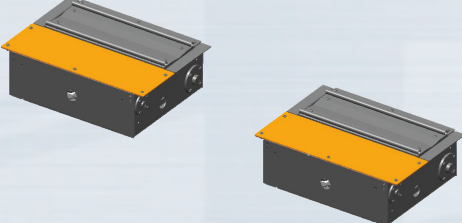
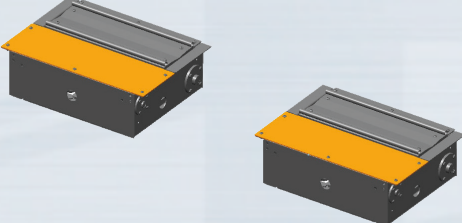
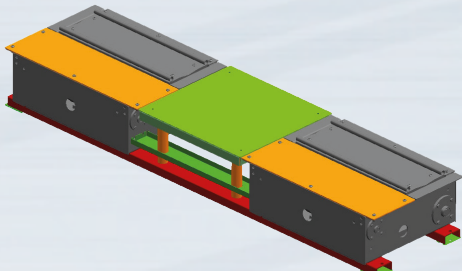
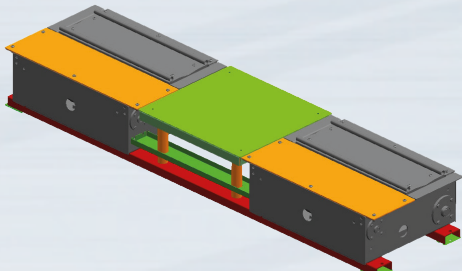
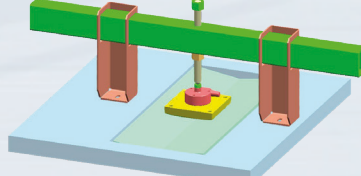
PN	Picture	Description
8-61200089		ST-NX - Suspension test bench (EUSAMA) - 230-400V/3PH/50Hz Motors: 2x3 kW Max. transit-up: 3000 kg Max. weight measurement: 2.500 kg.
8-61100043		ST-NX Kit for new installation or replacement of preexisting MB-ST in MB pit.
8-62200010		ST-NX - Suspension test bench (EUSAMA) - 230-400V/3PH/60Hz Motors: 2x3 kW Max. transit-up: 3000 kg Max. weight measurement: 2.500 kg.
8-61100043		ST-NX Kit for new installation or replacement of preexisting MB-ST in MB pit.
8-61200089		ST-NX - Suspension test bench (EUSAMA) - 230-400V/3PH/50Hz Motors: 2x3 kW Max. transit-up: 3000 kg Max. weight measurement: 2.500 kg.
8-61100047		ST-NX Kit for new install. or preexisting replacement. Podium installation.
806269367		Calibration device of suspension bench weighing unit. To match with digital display kit PN. 806268587

ADDITIONAL EQUIPMENT FOR PASSENGER CAR INSPECTION LINES

PN	Picture	Description	
5202000009		<p>Side slip plate Capacity: 2 T (connecting wire:15 m). For cars inspection lines only. Flush installation.</p>	

PASSENGER CAR INSPECTION LINES

Podium for on-floor installation inspection lines

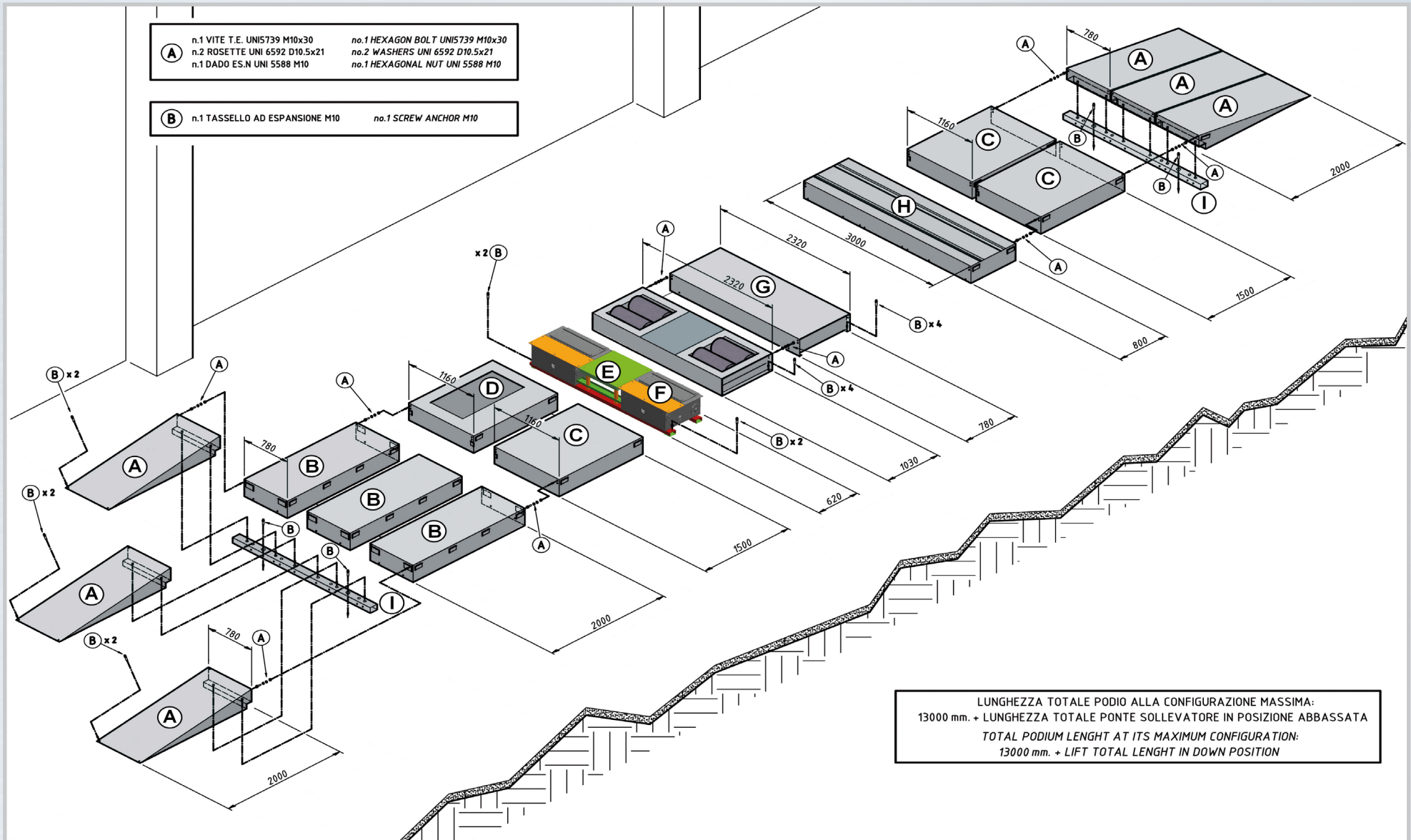

PASSENGER CAR INSPECTION LINES

Parts list

Pos.	PN	Description
C	806289299	Platform (1500 x 1160 mm.)
D	806289298	Side slip tester platform
E	8-61100047	Set of adapters for suspension tester
H	806285036A	Head light tester platform

PASSENGER CAR INSPECTION LINES

Podium recommended configurations

Pos.	PN	ASCENT SIDE				DESCENT SIDE			
		Config. 1	Config. 2	Config. 3	Config. 4	Config. 1	Config. 2	Config. 3	Config. 4
A	806.289300	2	3	2	3	2	3	2	3
B	806.289301	2	3	2	3	-	-	-	-
C	806.289299	2	2	1	1	2	2	2	2
D	806.289298	-	-	1	1	-	-	-	-
E	8-6110.00.47	1	1	1	1	-	-	-	-
F	8-6120.00.89	1	1	1	1	-	-	-	-
G	806.289474	1	1	1	1	-	-	-	-
H	806.285036A	-	-	-	-	-	-	1	1
I	806.389477	1	1	1	1	1	1	1	1
-	289475 (*)	1	1	1	1	1	1	1	1

* : Podium installation kit (including parts - smallware to fixing on floor each parts of podium).

Configurations list:

ASCENT SIDE

1. Podium without side slip tester housing and without central ramps.
2. Podium without side slip tester housing and with central ramps.
3. Podium with side slip tester housing and without central ramps.
4. Podium with side slip tester housing and with central ramps.

DESCENT SIDE

1. Podium without head light tester platform and without central ramps.
2. Podium without head light tester platform and with central ramps.
3. Podium with head light tester platform and without central ramps.
4. Podium with head light tester platform and with central ramps.

UNIVERSAL ROLLER BRAKE TESTERS FOR 2/3/4-WHEEL VEHICLES



VS UNIVERSAL



Main features:

- WINDOWS-based software
- "Reverse" system for 4WD vehicles. Operational program automatic or manual.
- Automatic stop of rollers on the adherence limit.
- Radio remote control and pedal brake pressure meter on request.
- Modular structure: it is possible to implement configurations for test on 2 wheels and 3-4 wheel vehicles.

PC AND PRINTER NOT INCLUDED!

REMOTE CONTROL KIT NOT INCLUDED!

Instrument cabinet:

Built-in 22" LCD colour monitor and keyboard as standard.

IEC standard electric panel.

WARNING! Roller bed, PC and printer, are NOT included in the standard configuration.
Please complete the order choosing in the "Completion devices" dedicated section.

Supplied with:
- Operator's manual.



VS UNIVERSAL

PN	Power supply	Description
0-61201001/61	400V/3Ph/50Hz	VS UNIVERSAL - Instrument cabinet. AVAILABLE UNTIL STOCKS LAST

WARNING! For different voltages a surcharge will be applied.



: New or Modified Item

UNIVERSAL ROLLER BRAKE TESTERS FOR 2/3/4-WHEEL VEHICLES



VS B UNIVERSAL



Main features:

- WINDOWS-based software
- "Reverse" system for 4WD vehicles. Operational program automatic or manual.
- Automatic stop of rollers on the adherence limit.
- Radio remote control and pedal brake pressure meter on request.
- Modular structure: it is possible to implement configurations for test on 2 wheels and 3-4 wheel vehicles.

PC AND PRINTER NOT INCLUDED!
REMOTE CONTROL KIT NOT INCLUDED!

Electric panel:

IEC standard electric panel for CAR roller brake tester.
Independent device to operate in absence of measuring cabinet.

WARNING!

Roller bed, PC and printer, are NOT included in the standard configuration.
Please complete the order choosing in the "Completion devices" dedicated section.

Supplied with:
- Operator's manual.



VS B UNIVERSAL

PN	Power supply	Description
0-61202001	400V/3Ph/50Hz	VS B UNIVERSAL - IEC standard electric panel for CAR roller brake tester

WARNING! For different voltages a surcharge will be applied.



 : New or Modified Item



COMPLETION DEVICES FOR VS UNIVERSAL

PN	Picture	Description
8-61220016/90	 <p>3Ph/ 400 V / 50 Hz</p>	<p>UNIVERSAL NG ROLLER BED</p> <ul style="list-style-type: none"> - Single bed set, - Max. weight 3000 kg, - Geared motors: 2x4 kW. - Rotation speed > 5 Km/h., - Shifted rollers L=1000 x D.200 mm. - Special plastic cement - coating gritted rollers. - Maximum track: 2200 mm. - Minimum track: 200 mm. - Adherence coefficient: 0,7 wet. - High precision strain gauge transducers. - Air wheel lifter <u>NOT</u> included. - Axle weighing unit under roller bed. <p>Note: the roller bed UNIVERSAL NG can be installed in preexisting pit of "5000 Series" roller bed.</p> <p>• Max braking force: 600 daN</p>
8-61200336		<p>Personalization kit for VS UNIVERSAL EXPORT.</p>
8-61200337		<p>Personalization kit for VS B UNIVERSAL EXPORT.</p>
8-61200208		<p>Frame for UNIVERSAL roller bed flush installation.</p>
8-61200213		<p>Adapting frame for UNIVERSAL roller bed installation in preexisting pit of "5000 Series" roller bed with weighing unit</p>

COMPLETION DEVICES FOR VS UNIVERSAL

PN	Picture	Description
8-61200271		IEC standard electric panel for BIKE roller brake tester. Preexisting CAR electric panel integration. Suitable for: VS UNIVERSAL and VS B UNIVERSAL.
8-61100086		CT universal radio remote control set. Suitable for: VS UNIVERSAL and VS B UNIVERSAL.
806468073		Set of pedal and hand brake pressure meter. Suitable for: VS UNIVERSAL and VS B UNIVERSAL.
8-61200206		Two-wheel completion kit for UNIVERSAL roller bed. Comprising: 1 Pair of sidewalks for roller bed. 1 Cover for rollers not in use.
806268640		Pair of integrated load cells. Integration for two-wheel completion kit for UNIVERSAL roller bed PN. 8-61200206.

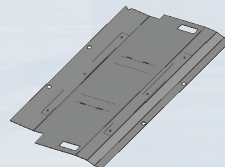
COMPLETION DEVICES FOR VS UNIVERSAL

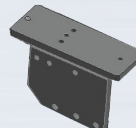
PN	Picture	Description
8-61200203		3/4-wheel completion kit for UNIVERSAL roller brake tester. Comprising: - Device for three-wheeler van brake pedal. - Device for three-wheeler van brake. - Emergency push-button with support.
8-61200214		UNIVERSAL roller bed carrying cover for rollers not in use - <u>RH Side</u> .
8-61220017		UNIVERSAL roller bed carrying cover for rollers not in use - <u>LH Side</u> .
8-61200192		Safety fastening kit for vehicle (Alternative to pair of clamps). Comprising: 1 Vehicle locking belt set. 1 Fastening handle set.
8-61200191		Calibration device of braking force complete with bar adaptor for UNIVERSAL brake tester. <u>Mandatory for 2-wheel and/or 3/4-wheel configurations.</u>
8-61200230		Bar adaptor kit for UNIVERSAL brake tester.

ROLLER BRAKE TESTERS FOR BIKES



COMPACT PRO MOTO



• Max. braking force: 300 daN

Supplied with:
- Operator's manual.



Main features:

- PC with DVD and windows-based software.
- "HELP" program is built-in and accessed by the operator before and after testing.
- INKJET Colour A4 printer and LCD colour monitor (On request).
- PC type alphanumeric keyboard, with "track-ball", for data input and test sequence selection.
- Operational program automatic or manual.
- IEC standard electric panel.
- Automatic stop of rollers on the adherence limit.

MONITOR AND PRINTER NOT INCLUDED!

Instrument cabinet:

- Radio remote control.
- Dinamometer signals transmitter.
- Emergency push-button.

Roller bed:

- Single roller bed
- Max. weight: 500 kg
- Geared motor: 2,2 kW
- Rotation speed: 5 km/h
- Shifted rollers L=375 x D. 204 mm
- Special plastic cement - coating gritted rollers
- Adherence coefficient: 0,8
- High precision strain gauge transducers
- Weighing unit included

WARNING!

Monitor and printer, are NOT included in the standard configuration. Please complete the order choosing in the "Additional accessories..." dedicated section.

COMPACT PRO MOTO

PN	Power supply	Description
0-61203901/61	400V/3Ph/50Hz	COMPACT PRO MOTO - EXP - Instrument cabinet + Roller bed

WARNING! For different voltages a surcharge will be applied.





: New or Modified Item

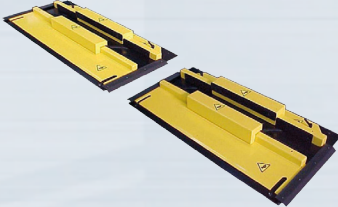

OPTIONAL ACCESSORIES FOR BIKE ROLLER BRAKE TESTERS

PN	Picture	Description
8-61200237		A4 color inkjet printer set - USB Connection.
8-21100235		19" Widescreen LCD monitor for COMPACT PRO MOTO.
8-61200143		LCD monitor support for COMPACT PRO MOTO.

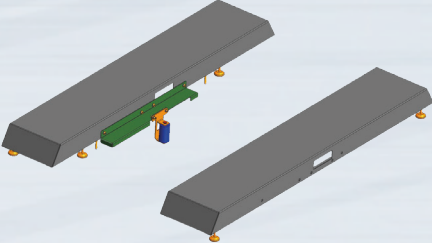
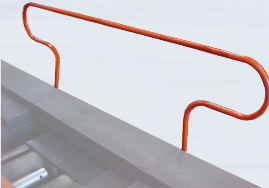
ADDITIONAL EQUIPMENT FOR BIKE INSPECTION LINES

PN	Picture	Description
806269271		Frame for bike roller bed for flush installation. To be used exclusively for testing lines with low asymmetric clamps PN 806269344. To order preventively.
806269344		Pair of low pneumatic asymmetric clamps for flush installation. Without sidewalks.
806269272		Frame for low pneumatic asymmetric clamp for flush installation. To order preventively (Q.ty: 2 pcs.).
8-61220008		Sidewalks set for stand-alone bike roller bed.
806268632		Support for control boxes. Complete with brackets. For flush and on-floor installation.

ADDITIONAL EQUIPMENT FOR BIKE INSPECTION LINES

PN	Picture	Description	
8-61200091	 <p style="text-align: center;">CLAMPS NOT INCLUDED!</p>	<p>Complete podium for on-floor installation. To match with low pneumatic asymmetric clamps PN. 806269344 (Not included in delivery).</p>	
806268198		<p>Complete calibration device of braking force.</p>	

SUSPENSION TESTERS FOR PASSENGER CARS AND VANS



COMPACT PRO W ST-NX

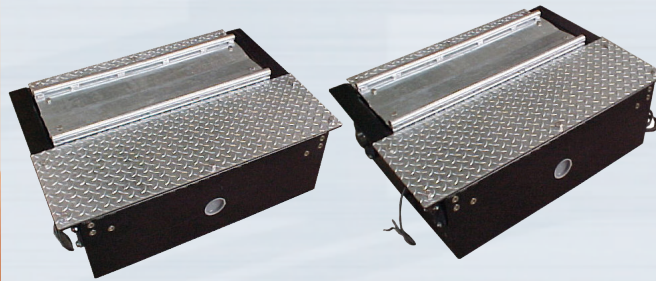

Supplied with:
- Operator's manual.



Main features:

- Test of the efficiency of suspensions on cars and light vehicles, measuring the adherence value according to the EUSAMA measuring method.
- Measurement of the minimum dynamic load and the static load on the wheel, and then the calculation of the quotient between the two values.
- PC with WINDOWS-based software.
- PC type alphanumeric keyboard, with "track-ball", for data input and test sequence selection.
- IEC standard electric panel

MONITOR AND PRINTER NOT INCLUDED!

Instrument cabinet:

- LCD color monitor (Optional).
- A4 INKJET colour printer (Optional)

Suspension test bench:

"Stand-alone" installation version.

Flush installation.

- Motors: 2x3 KW
- Max. transit-up: 3000 kg
- Max. weight measurement: 2500 kg

WARNING!

Monitor and printer, are NOT included in the standard configuration. Please complete the order choosing in the "Additional accessories..." dedicated section.

COMPACT PRO W ST-NX

PN	Power supply	Description
0-62200302/61	230V/1Ph/50Hz	COMPACT PRO W ST-NX - Instrument cabinet + Suspension test bench.
8-61100043	400V/3Ph/50Hz	"Stand-alone" flush installation version set.

WARNING! For different voltages a surcharge will be applied.



: New or Modified Item

SUSPENSION TESTERS FOR PASSENGER CARS AND VANS



COMPACT PRO W ST-NX

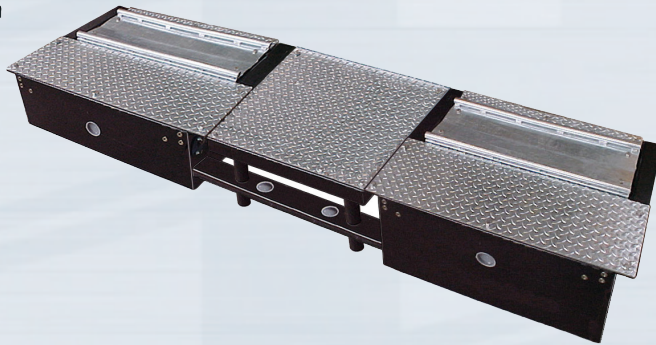

Supplied with:
- Operator's manual.



Main features:

- Test of the efficiency of suspensions on cars and light vehicles, measuring the adherence value according to the EUSAMA measuring method.
- Measurement of the minimum dynamic load and the static load on the wheel, and then the calculation of the quotient between the two values.
- PC with WINDOWS-based software.
- PC type alphanumeric keyboard, with "track-ball", for data input and test sequence selection.
- IEC standard electric panel

MONITOR AND PRINTER NOT INCLUDED!

Instrument cabinet:

- LCD color monitor (Optional).
- A4 INKJET colour printer (Optional)

Suspension test bench:

"Stand-alone" installation version.

Podium installation.

- Motors: 2x3 KW
- Max. transit-up: 3000 kg
- Max. weight measurement: 2500 kg

WARNING!

Monitor and printer, are NOT included in the standard configuration. Please complete the order choosing in the "Additional accessories..." dedicated section.





COMPACT PRO W ST-NX

PN	Power supply	Description
0-62200302/61	230V/1Ph/50Hz	COMPACT PRO W ST-NX - Instrument cabinet + Suspension test bench.
8-61100047		"Stand-alone" podium installation version set.



: New or Modified Item

OPTIONAL ACCESSORIES FOR COMPACT PRO W ST-NX

PN	Picture	Description
8-61200237		A4 color inkjet printer set - USB Connection.
8-21100235		19" Widescreen LCD monitor for COMPACT PRO MOTO.
8-61200143		LCD monitor support for COMPACT PRO MOTO.
8-61100086		CT universal radio remote control set .
8-61200146		Infrared remote control set .

UNIVERSAL PLAY DETECTOR



PD 689533

Class 2



Supplied with:

- Moving floor plates: 4+4 motions;
- 16 T max. (for axle) transit-up;
- 13 T max. (for axle) weight measurement.
- Motor: 1x3 kW
- Hydraulic pump station
- Electric control box
- Remote control with built-in lamp
- Pedal depressor
- Operator's manual

OIL PIPES NOT INCLUDED!



• Note: By ordering always state the kind of installation you need (1703 or 1704).

PD 689533

PN	Power supply	Description
0-62200701/34	400V/3Ph/50Hz	PD 689533 - Universal play detector for passenger cars and trucks.



: New or Modified Item

WARNING! For different voltages a surcharge will be applied.

- Compatible accessory supplied as STANDARD.
- Compatible accessory supplied on REQUEST.

ACCESSORIES FOR UNIVERSAL PLAY DETECTOR

WARNING! The hydraulic connection pipes are not included in the standard configuration.
Please refer to the list shown here below:

PN	PICTURE	Description
806269497		Flexible oil hose L = 6,4 m.
806269498		Flexible oil hose L = 7,1 m.
806269499		Flexible oil hose L = 1,0 m

ORDER SPECIFICATIONS FOR PIPELINE LENGTHS ON THE BASIS OF DISTANCE BETWEEN CONTROL UNIT AND OSCILLATING PLATES

DISTANCE REQUIRED (mm)

HOSE REFERENCE

Q.TY TO ORDER

- From a 2850 mm. min.
up to 3650 mm.

806.269497 (length. 6,4 m.)

4

- With larger than or different dimensions.
from those indicated above.



806.269498 (length. 7,1 m.)

4

806.269499 (length. 1,0 m.)

*

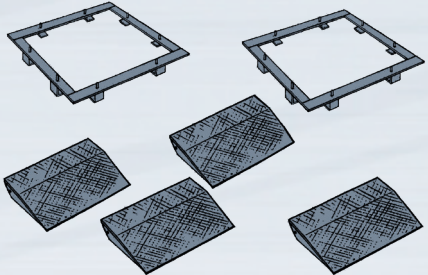
*: To be order "n" extensions of 1 m. in length up to reach the length required.

1703000009		Set of 2 pcs. frames for moving floor plates (Floor installation). (Included 4 drive-on ramps).
1704000009		Set of 2 pcs. frames for moving plates (Flush installation)

PASSENGER CAR PLAY DETECTOR



PD 622

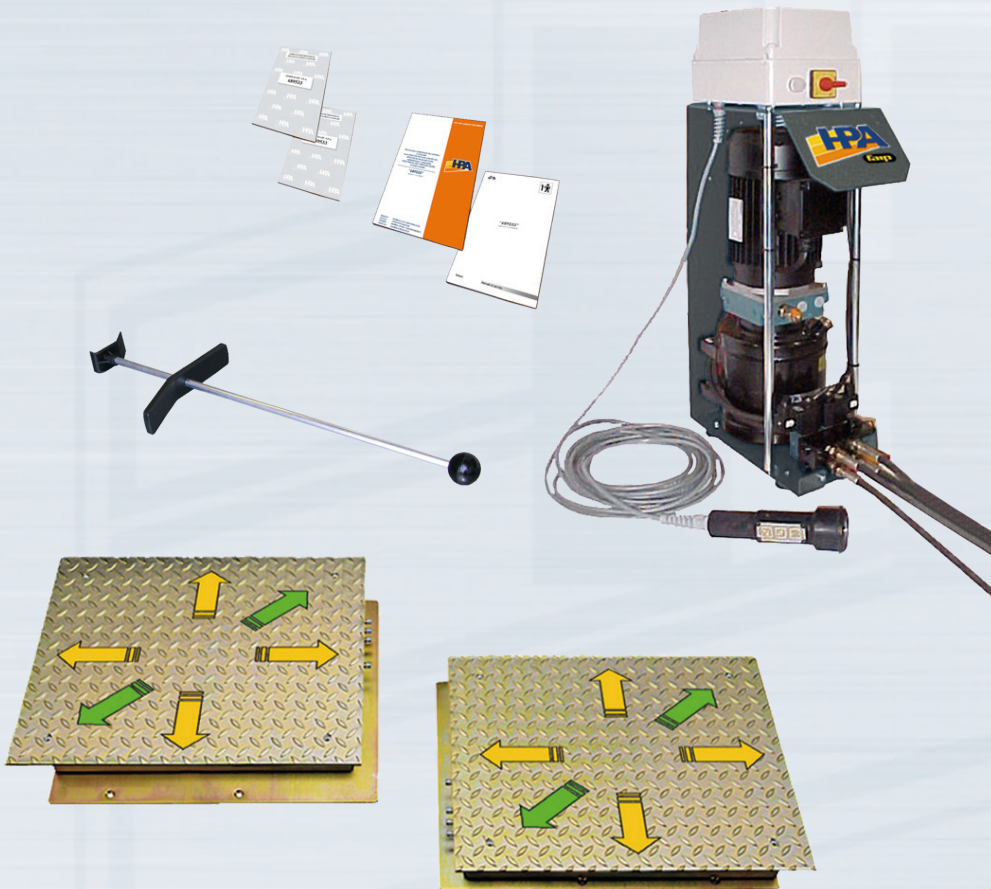

Supplied with:

- Moving floor plates, 6 motions;
- 3 T max. (for axle) transit-up;
- 2.5 T max. (for axle) weight measurement.
- Motor: 1x1,5 kW.
- Hydraulic pump station
- Electric control box
- Remote control with built-in lamp.
- Pedal depressor
- Operator's manual.



1 x 1,5 kW

PD 622

PN	Power supply	Description
0-62200901/34	400V/3Ph/50Hz	PD 622 Via cable play detector for passenger cars and vans.

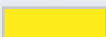

 : New or Modified Item

WARNING! For different voltages a surcharge will be applied.

CAMERA HEAD LIGHT TESTERS



PFT-CAM



Main features:

- Trolley mounted version.
- Display: 5.7" touch screen.
- Power supply: internal rechargeable battery (12 V DC).
- Laser Alignment. Language: Italian / English (Other languages available on request).

Measuring ranges:

- Brightness: 0-150.000 (lux/1m); 0-240 lux (lux/25m).

Input/Output:

- RS232 serial interface with DB9 connector.
- USB port for firmware update.

Complete with:

- Trolley
- Serial connection cable
- Battery Charger/AC adapter
- Operator's manual

PFT-CAM

PN	Power supply	Description
0-65500401/34		PFT-CAM - LASER Alignment. Trolley mounted version.



: New or Modified Item

ACCESSORIES FOR CAMERA HEAD LIGHT TESTERS

PN	Picture	Description
806285321		Set of rails L= 3600 mm. Flush installation.
1336000009		Set of rail extension L= 1250 mm. Flush installation.
8-65500002		Wheel kit for rails.
8-65500005		Calibration set (For Technical support Centres only).

DIGITAL HEAD LIGHT TESTERS



LOOK "LS"

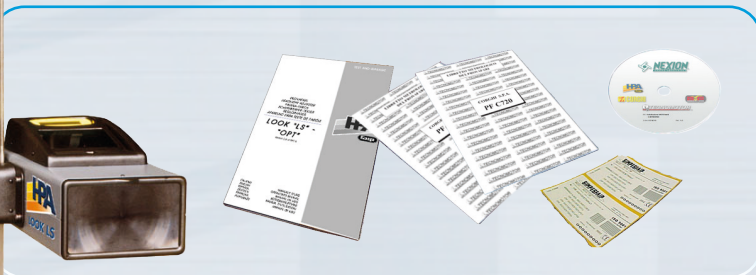

Main features:

- Electronic head light testers.
- Digital Luxmeter with candle and "lux" reading scale.
- Pre-set to remote control unit link.
- Optical glass lens. Tests repeatability.
- 12 languages are available.
- 9V internal self-supply and external supply pre-setting.
- Available both in right- and left-hand drive version (to be stated by ordering).

All model supplied with:
- Operator's manual.



LOOK "LS"

PN	Power supply	Description
0-65200301/31 *		LOOK LS - LASER alignment - LH-hand drive - Trolley mounted version.
0-65200501/31 *		LOOK LS - LASER alignment - RH-hand drive - Trolley mounted version.

* : to optain a rail versionhead light tester, please complete the order with the kit PN 8-62200002 (see next page)



: New or Modified Item

DIGITAL HEAD LIGHT TESTERS



LOOK "OPT"

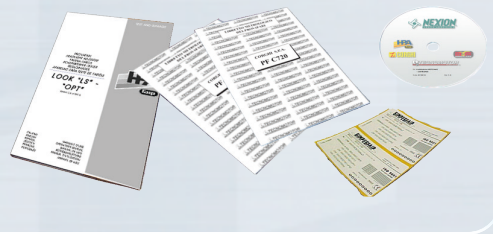

Main features:

- Electronic head light testers.
- Digital Luxmeter with candle and "lux" reading scale.
- Pre-set to remote control unit link.
- Optical glass lens. Tests repeatability.
- 12 languages are available.
- 9V internal self-supply and external supply pre-setting.
- Available both in right- and left-hand drive version (to be stated by ordering).

All model supplied with:
- Operator's manual.



LOOK "OPT"



PN	Power supply	Description
0-65200401/31 *		LOOK OPT - OPTICAL alignment - LH-hand drive - Trolley mounted version.
0-65200601/31		LOOK OPT - OPTICAL alignment - RH-hand drive - Trolley mounted version.

* : to obtain a rail version head light tester, please complete the order with the kit PN 8-62200002 (see next page)

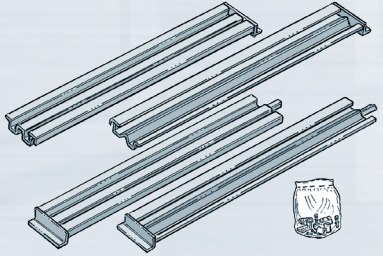
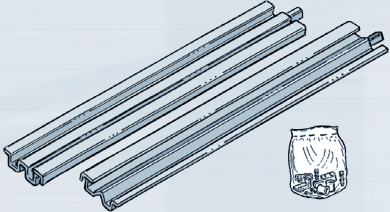
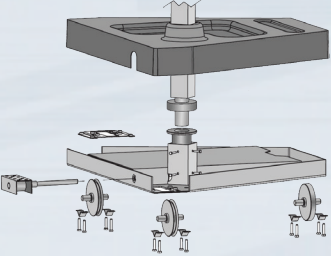

: New or Modified Item

ACCESSORIES FOR DIGITAL HEAD LIGHT TESTERS

PN	Picture	Description
806285321		Set of rails L = 3600 mm. Flush installation.
133600009		Set of rail extension L= 1250 mm. Flush installation.
8-62200002		Kit to modify a head light tester from trolley version to rail version.
8-62500001		220V/9V External power supply.

GAS ANALYSERS



810 - 830



810

Independent unit with 4x20 LCD high visibility display.
Integrated thermal stripe printer.
Handle and ergonomic keyboard.



830

MULTILANGUAGE
"Client" unit for installation on multifunction testing lines.
Support brackets for portable module use, supplied as standard.

Main features:

- Exhaust gas analysers for gasoline, CNG (Compressed Natural Gas) and LPG engines.
- Serial interface for installation on multifunction testing lines.
- 5 exhaust analysis: CO - CO₂ - HC - O₂ and NOX (with NO sensor option only).
- Lambda probe analysis.
- RPM and engine oil temperature measurement (with additional probes only).
- Integrated connectors: 1 RS232 serial port, 1 PS2 port.
- Temperature probe: 5 ÷ 40°C
- Wireless source with dedicated battery kit (optional)

MULTILANGUAGE

"Client" unit for installation on multifunction testing lines.
Support brackets for portable module use, supplied as standard.

SUPPLIED WITH:

- 1 Serial cable for PC interface.
- 1 CD-ROM with PC Router software
- 1 Gas takeoff probe
- 1 Operator's manual









810 - 830

PN	Power supply	Description
0-64502111	110-230V/1Ph/50-60Hz	810 - Independent unit with LCD display - EN
0-64502131	110-230V/1Ph/50-60Hz	810 - Independent unit with LCD display - ES
0-64502141	110-230V/1Ph/50-60Hz	810 - Independent unit with LCD display - PT
0-64502161	110-230V/1Ph/50-60Hz	810 - Independent unit with LCD display - GREEK
0-64503201	110-230V/1Ph/50-60Hz	830 - "Client" unit for installation on multifunction testing lines

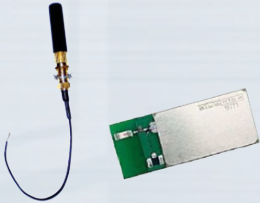



 : New or Modified Item

ACCESSORIES FOR 810 AND 830 GAS ANALYSERS

PN	Picture	Description
8-64500003		Internal Bluetooth slave radio module for gas analyser.
6011000007		Bluetooth kit for RPM counter EOBD/GAS/OPA.
8-64500001		Internal battery kit
8-64500002		USB/RS232 cable adapter.
8-63500002		Oil temperature probe.
8-64200009		Adapter kit for motorbike exhaust. Complete with accessories.

ACCESSORIES FOR 810 AND 830 GAS ANALYSERS

PN	Picture	Description	
8-64200135		<p>Trolley for analyser.</p>	
8-64200134		<p>Trolley with support for analyser.</p>	

GAS ANALYSERS

COMPLETE CONFIGURATIONS FOR 810 AND 830 GAS ANALYSERS

ALL CONFIGURATION SUPPLIED WITH:

- 1 Serial cable for PC interface.
- 1 CD-ROM with PC Router software
- 1 Gas takeoff probe
- 1 Operator's manual



PN	Picture	Description
0-64502112		<p>810 gas analyser basic module. (110-230V/1Ph/50-60Hz). Integrated with:</p> <ul style="list-style-type: none"> - Internal battery kit. - Internal Bluetooth slave radio module.
0-64503202		<p>830 gas analyser basic module. (110-230V/1Ph/50-60Hz). Integrated with:</p> <ul style="list-style-type: none"> - Internal battery kit. - Internal Bluetooth slave radio module

SMOKE METERS



820 - 840



820

Independent unit with 4x20 LCD high visibility display. Integrated thermal stripe printer. Handle and ergonomic keyboard.

Main features:

- Partial flow smoke meter for Diesel engines.
- Serial interface for installation on multifunction testing lines.
- RPM and engine oil temperature measurement (with additional probes only).
- Integrated connectors: 1 RS232 serial port, 1 PS2 port.
- Temperature probe: 5 ÷ 40°C
- Wireless source with dedicated battery kit (optional).



840

“Client” unit for installation on multifunction testing lines. Support brackets for portable module use, supplied as standard.

SUPPLIED WITH:

- 1 Serial cable for PC interface.
- 1 CD-ROM with PC Router software .
- 1 Gas takeoff probe with pincer fastening probes to exhaust.
- 1 Operator’s manual.









820 - 840

PN	Power supply	Description
0-64502311	110-230V/1Ph/50-60Hz	820 - Independent unit with LCD display - EN
0-64502331	110-230V/1Ph/50-60Hz	820 - Independent unit with LCD display - ES
0-64502341	110-230V/1Ph/50-60Hz	820 - Independent unit with LCD display - PT
0-64502361	110-230V/1Ph/50-60Hz	820 - Independent unit with LCD display - Greek
0-64503401	110-230V/1Ph/50-60Hz	840 - “Client” unit for installation on multifunction testing lines

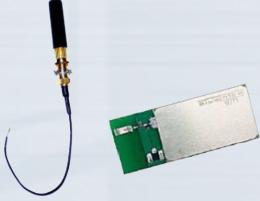



: New or Modified Item

ACCESSORIES FOR 820 AND 840 SMOKE METERS

PN	Picture	Description
8-6450009		Internal Bluetooth slave radio module for smoke meter.
601100007		Bluetooth for RPM counter EOBD/GAS/OPA.
8-6450001		Internal battery kit .
8-6450002		USB/RS232 cable adapter.
8-6350002		Oil temperature probe .
8-6350011		Smokes probe for trucks.

ACCESSORIES FOR 820 AND 840 SMOKE METERS

PN	Picture	Description	
8-64200135		<p>Trolley for smoke meter.</p>	
8-64200134		<p>Trolley with support for analyser.</p>	

SMOKE METERS

COMPLETE CONFIGURATIONS FOR 820 AND 840 SMOKE METERS

ALL CONFIGURATIONS SUPPLIED WITH:

- 1 Serial cable for PC interface.
- 1 CD-ROM with PC Router software .
- 1 Gas takeoff probe with pincer fastening probes to exhaust.
- 1 Operator's manual.



PN	Picture	Description
0-64502312		<p>820 smoke meter basic module (110-230V/1Ph/50-60Hz). Integrated with:</p> <ul style="list-style-type: none"> - Internal battery kit. - Internal Bluetooth slave radio module.
0-64503402		<p>840 smoke meter basic module (110-230V/1Ph/50-60Hz). Integrated with:</p> <ul style="list-style-type: none"> - Internal battery kit. - Internal Bluetooth slave radio module



RPM COUNTER 165



Main features:

- Approved universal RPM counter for gasoline and diesel engines.
- RPM and oil temperature measurement directly from vehicle EOBD socket or directly RPM measurement only by means of battery.
- Stand-alone instruments with 3-inch graphic LCD display, 128x64 pixel, transfective and 7 key keyboard.
- Integrated Bluetooth and internal battery for real time data transmission to PC.
- Lithium battery with more than one week autonomy testing 30 vehicles/day.
- Multilanguages: I, GB, F, E, PT, D, NL, PL.
- Protection: IP54.

Supplied with:

- 1 Operator's manual
- 1 EOBD Measurement cable
- 1 From battery and oil temperature measurement cable (In combination with accessory PN 8-6350.00.06)

RPM COUNTER 165

PN	Power supply	Description
8-64503065		RPM counter 165 + kit RPM battery

ACCESSORIES FOR RPM COUNTER 165





PN	Picture	Description
8-64502016		Accessory for RPM measurement from battery. EOBD cable/Battery connexion.
8-64502068		RPM from battery and oil temperature measurement accessory. EOBD cable/Battery (not cigarette lighter socket) connexion + Oil temperature probe. In combination with PN 8-63500006. Supplied with kit PN. 8-64502065.
8-63502007		Vibration RPM adapter .
8-63500006		Oil temperature probe Longer Cable to be matched with PN. 8-64502068.
6011000007		Bluetooth kit for EOBD RPM counter.

DIAGRAM OF PACKING SPECIFICATION

TESTING EQUIPMENT

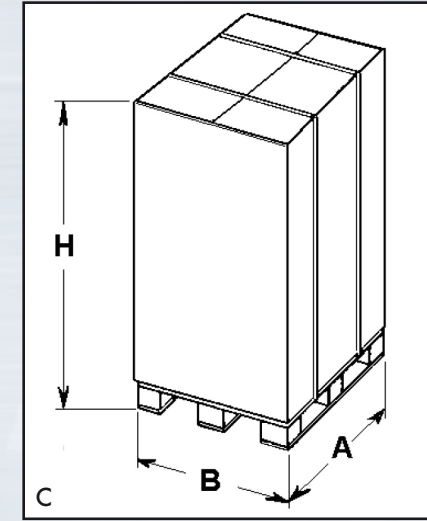
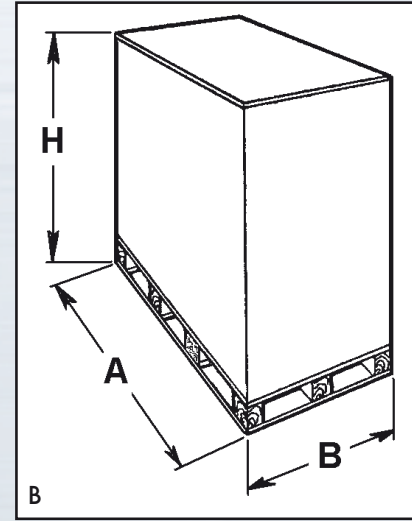
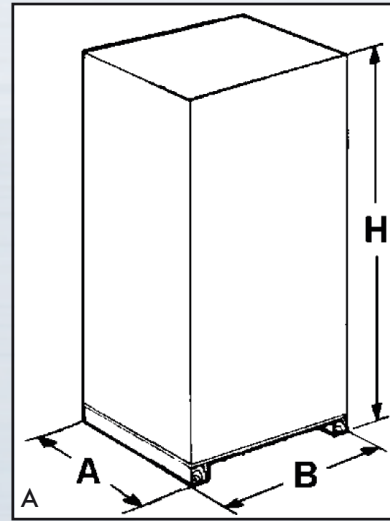

Model	Packing type	Dimensions (cm.) (A x B x H)	Net weight (kg)	Gross weight (kg)
ROLLER BRAKE TESTERS for TRUCKS and BUSES				
VIDEOSYSTEM P150 / P110 - Cabinet	Wooden case (A)	102x 87x203	160	190
Roller bed 2x15 kW / 2x11 kW	Pallet x 2	150x132x 60 (x2)	1570	1600
VIDEOSYSTEM W - Cabinet	Wooden case (A)	102x 87x203	160	190
COMPACT PRO W - Cabinet	Wooden case (B)	116x 76x145	107	140
Roller bed 4 kW	Pallet	232x 95x 48	465	485
VS UNIVERSAL Cabinet	Wooden case (A)	102x 87x203	160	190
VS B UNIVERSAL - Box	Carton box	130x 60x 26	50	70
Roller bed 4 VS UNIVERSAL	Pallet	235x 95x 48	620	640
MAIN OPTIONALS FOR INSPECTION LINES				
8-61200089 - ST-NX Suspension tester bench	Wooden case (B)	135x 92x 41	280	315
8-61200025	Pallet	243x 46x 27	—	200
8-61200027	"	215x 95x 35	—	140

Model	Packing type	Dimensions (cm.) (A x B x H)	Net weight (kg)	Gross weight (kg)
ROLLER BRAKE TESTERS for BIKES				
COMPACT PRO MOTO - Cabinet	Wooden case (B)	152x 87x145	120	155
COMPACT PRO MOTO - Roller bed	Pallet	150x 65x 40	215	230
806269344 - Low asymmetric clamps kit	"	135x 65x 40		
806268198 - Calibrator kit BIKE Roller bed	Wooden case (B)	121x 29x 31		
8-61200091 - Podium kit for BIKE LINE	Pallet	202x121x102		
ST-NX "STAND ALONE" SUSPENSION TESTER				
COMPACT PRO W ST-NX - Cabinet	Wooden case (B)	116x 76x145	95	130
8-61200089 - ST-NX Tester bench	Cassa in legno (B)	135x 92x 41	280	315
PLAY DETECTORS				
PD 689533 - Electric and hydraulic box	Wooden case (B)	52x 82x 84	60	80
PD 689533 - Moving plates	Pallet	80x120x 40	430	450
HEAD LIGHT TESTERS				
PFT-CAM	Carton box	63x180x 66	30	40
LOOK - Head light testers	"	66x 71x 43	25	30
LOOK - Rod for head light testers	"	07x 07x173	2,5	3
LOOK - Rail set	Strapped pack	200x 15x 17		20



in the world

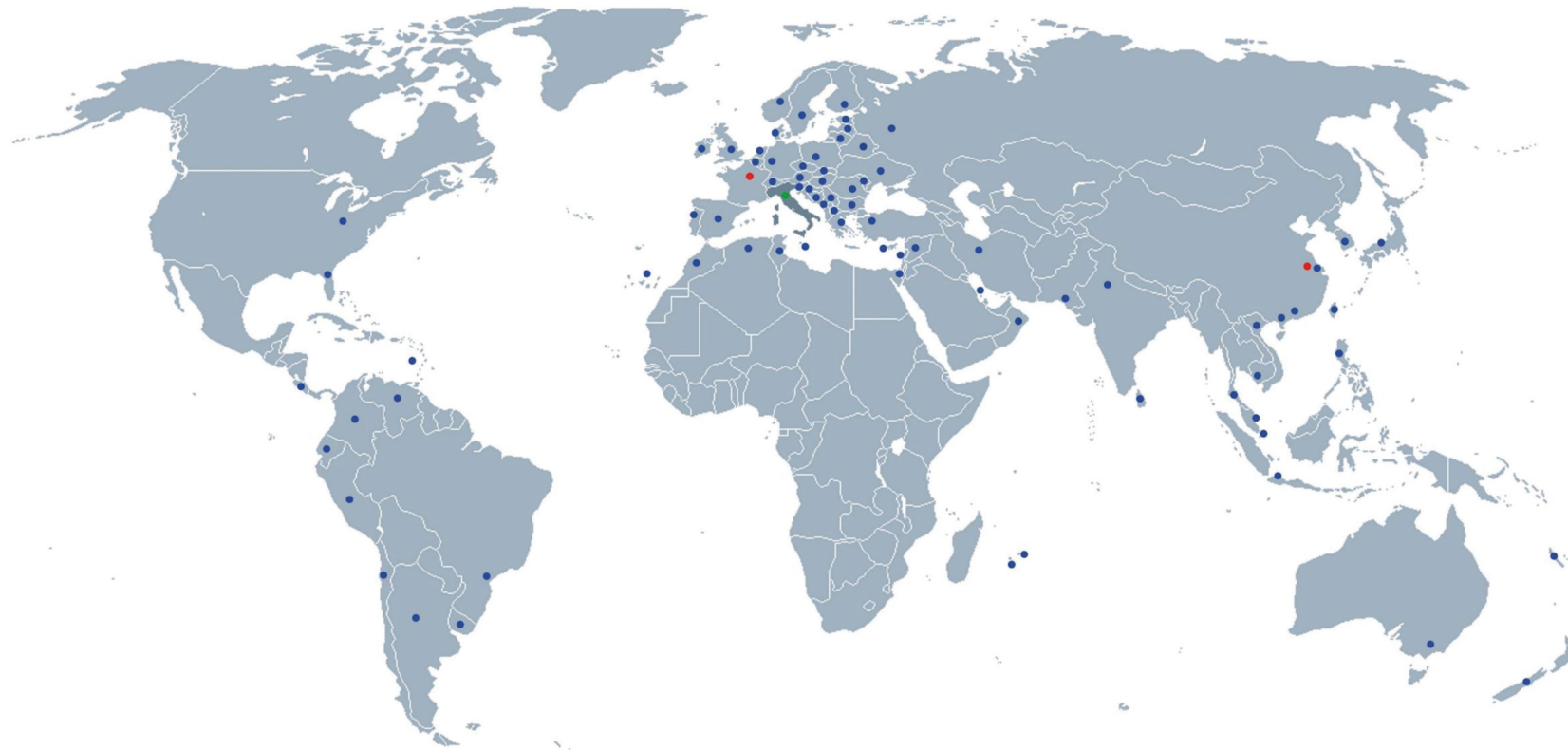

- : HPA-FAIP branch offices in the world.
- : HPA-FAIP distributors.
- : HPA-FAIP head office.

Sales and after-sales network:

- | | | | | | | | |
|-------------|------------------|-----------------|-------------|---------------------|---------------------|----------------------|-------------|
| ● ALGERIA | ● CAMBODIA | ● ECUADOR | ● INDIA | ● MACAO | ● NEW ZEALAND | ● RUSSIAN FEDERATION | ● TAIWAN |
| ● ARGENTINA | ● CANARY ISLANDS | ● ESTONIA | ● INDONESIA | ● MACEDONIA | ● NORWAY | ● SERBIA | ● THAILAND |
| ● AUSTRALIA | ● CHILE | ● FINLAND | ● IRAN | ● MALAYSIA | ● OMAN | ● SINGAPORE | ● THAILAND |
| ● AUSTRIA | ● CHINA (RP) | ● FRANCE | ● IRELAND | ● MALTA | ● PAKISTAN | ● SLOVAK REPUBLIC | ● TURKEY |
| ● BAHRAIN | ● COLOMBIA | ● GERMANY | ● ISRAEL | ● MARTINICA | ● PERU | ● SLOVENIA | ● UKRAINE |
| ● BELARUS | ● COSTA RICA | ● GREAT BRITAIN | ● JAPAN | ● MAURITIUS | ● PHILIPPINES (THE) | ● SPAIN | ● URUGUAY |
| ● BELGIUM | ● CROATIA | ● GREECE | ● KOSOVO | ● MONTENEGRO | ● POLAND | ● SRI LANKA | ● U.S.A. |
| ● BOSNIA | ● CYPRUS | ● HONG KONG | ● LATVIA | ● MOROCCO | ● PORTUGAL | ● SWEDEN | ● VENEZUELA |
| ● BRAZIL | ● CZECH REPUBLIC | ● HUNGARY | ● LEBANON | ● NETHERLANDS (THE) | ● REUNION ISLAND | ● SWITZERLAND | ● VIETNAM |
| ● BULGARIA | ● DENMARK | ● KOREA (SOUTH) | ● LITHUANIA | ● NEW CALEDONIA | ● ROMANIA | ● SYRIA | |
| ● CAMBODIA | ● ECUADOR | | | | | | |



■ : New or Modified Item

- Compatible accessory supplied as STANDARD.
- Compatible accessory supplied on REQUEST.

GENERAL SALE CONDITIONS

- The present export price-list, covering standard production equipment, replaces all previous ones.
- Goods are delivered FCA WAREHOUSE CORREGGIO - Incoterms® 2010, ICC Paris and shipped at buyer's cost.
- Standard packing is included in the price of each product.
- When ordering please always state model, quantity, power supply (Voltage, Phases, Hz) required.
- Terms of warranty: 12 months from installation date but no longer than 18 months from the date of NEXION S.p.A. invoice.
- The warranty does not cover defects or damages due to improper installation or use of products, inadequate maintenance or uncomplete knowledge of manuals supplied with the products.
- Any return of goods must always be authorized by NEXION S.p.A. and will be accepted only free our factory, custom cleared. Freight is at sender's risk.
- NEXION S.p.A. reserves the right to change the specifications of the products at any time without prior notice or obligation.

WARNING!

For other conditions please refer to the "Distribution Agreement".



**COMPANY WITH
CERTIFIED
QUALITY SYSTEM
- ISO 9001-**

