

**NEW**

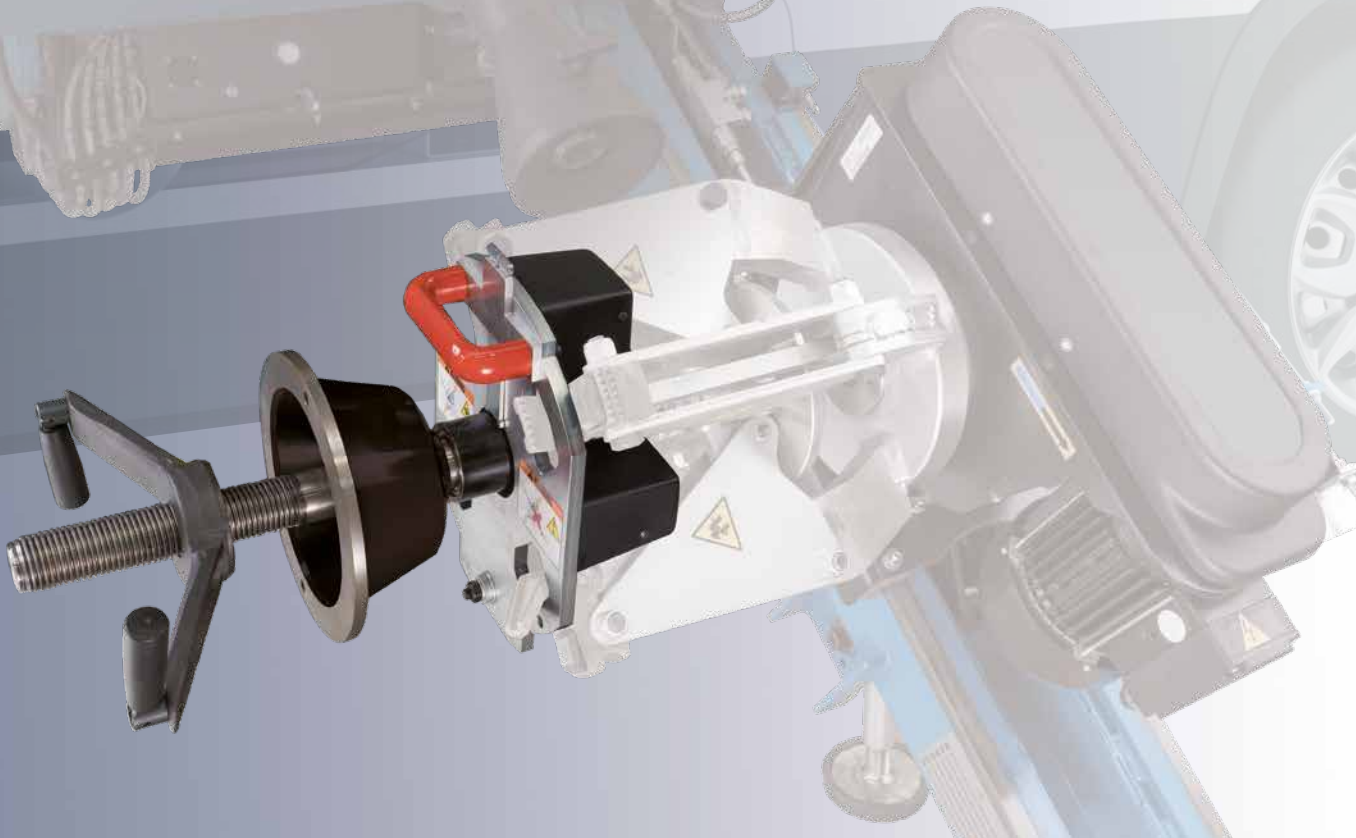

**PORTABLE DISPLAY**



**HPA**  
**Faip**



Portable wheel balancer  
for truck, bus, light transport  
and car wheels

**T 500 Truck**

# T 500 Truck

## Portable wheel balancer for truck, bus, light transport and car wheels.

### Main features

- ❑ **Compact and light wheel balancer** for truck and bus wheels
- ❑ **Small size and weight** facilitate movement and use
- ❑ **Easy and quick mounting system** on any type of truck tyre changer.
- ❑ Suitable for mobile service and for those who have little room the workshop
- ❑ **Low rotation speed**
- ❑ **Manual wheel size launch and entry**
- ❑ **Weather-resistant** thanks to IP41 protection
- ❑ Complete with **all balancing programs**:  
Dynamic - Static and ALU for alloy rims.



- ❑ **Portable, magnetically fixed display**, powered with **rechargeable batteries** and easy to use



- ❑ Complete with **support for housing the measuring unit**, display and centring kit



### Technical specifications

Power supply	12Vdc 115÷230 Vac 50/60Hz 0,018kW
Protection rating	IP41
Shaft diameter	40mm
Cycle time per wheel	8 ÷ 20 s
Balancing speed	< 70 rpm
Measurement uncertainty	10g
Average noise	< 70dB(a)
Settable rim width	1,5" ÷ 20" (40 ÷ 510 mm)
Settable diameter	10" ÷ 30" (265 ÷ 765 mm)
Maximum wheel weight	< 250 kg
Machine weight	~ 20 kg

### Overall dimensions

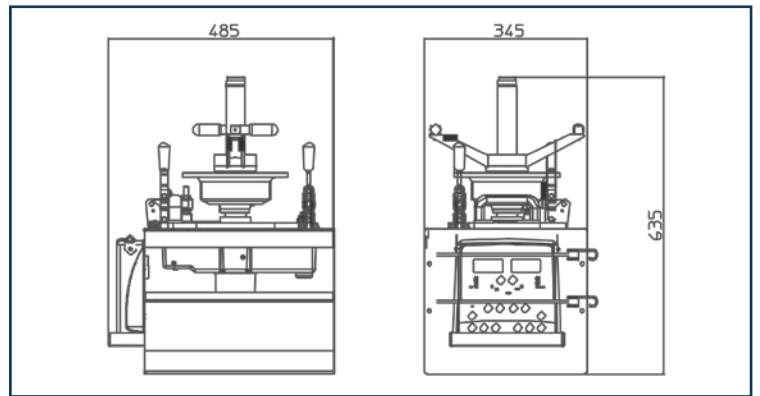

### Equipment



### Recommended accessories

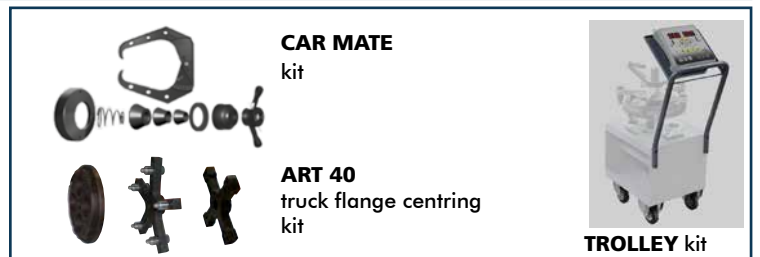

The illustrations, configurations and technical features in this publication are intended to present the product only, and are subject to variation. To ensure correct ordering, always refer to the current price list.



NEXION S.p.A.  
www.hpa-faip.it - info@hpa-faip.it



 Made in Italy

DPSF000421A-06/22